

Materials List for 6x8 Portable Wood Cowbird Trap

| Number | Description | Comments |
|--------------|---------------------------|---|
| 16 | 2x4x8 (treated) | Rip 2x4 into 2x2 |
| 2 | Sheets ½” CDX plywood | 1 sheet is for slot assembly, 1 sheet is |
| 64 linear ft | ½” mesh hailscreen | to cut up for gussets. Bought in 100 ft. rolls |
| 1 pair | Tight pin hinges (3”) | Door hinges |
| 1 | Screen door-handle | Outside of door |
| 1 | Galvanized hasp (4½”) | Use with padlock for security |
| 1 | Screen door latch | Used on inside of door |
| 14 | 10”x12” shelf brackets | Used to square panels (2 per panel) |
| 125 (approx) | 1” drywall screws | Field assembly of slot |
| | | attaching shelf brackets to panels. |
| 50 (approx) | 3” galvanized deck screws | Field assembly (panel to panel) |
| 300 (approx) | 1½” pneumatic staples | Used attach gussets |
| 600 (approx) | 1 pneumatic staples | Used to attach screen to panels |
| 300 (approx) | ½” staples | Used to attach screen to slot |
| | | assembly |

Recommended Tools For Construction

Shop Assembly of Panels

- Table saw – for ripping 2x2
- Chop saw – for cutting boards to length
- Electric hand saw – for cutting out gussets and slot assembly
- Retractable rule – for measuring dimensions
- Electric or cordless drill/driver – for driving screws
- Pneumatic or electric nibbler – for cutting hail screen
- Pneumatic stapler – for attaching gussets and wire
- Pneumatic nailer – for assembly of panels
(optional but helpful – Panels can be assembled with 3” deck screws if nailer is not available.)

Field Assembly

- Cordless drill/driver – for driving screws
- Bar of soap – to lubricate screw threads
- Hand stapler – to secure wire to ends of drop entrance
- Step ladder – for attaching top panels

Construction Tips

- Use treated lumber throughout. Added initial cost is compensated for by longer field life and reduced maintenance.
- Don't rip lumber until you are ready to start construction. Ripped lumber will bow and twist if allowed to sit for several days.
- Use a shelf bracket on diagonal corners to square each panel before attaching gussets. To cut gussets, lay out sheet of plywood in 12" squares, then draw diagonals across the square. A sheet of plywood will make 64 gussets.
- Gussets go on one side of panel, hailscreen attaches to the other side. For side and top panels, wire will end up being on the inside on the panel. This prevents birds from roosting on framework next to wire where they are prone to predation. **Exception:** End panels are constructed the same way, but during final trap assembly, the wire goes on the outside, because the drop entrance attaches to horizontal members for structural stability.
- This pattern is designed to use 48" wide hailscreen to maximize efficiency. Internal cross members are placed to allow for slight overlap. Wide hailscreen will probably not be readily available in stock, but any building supply can order it. Use of narrower hailscreen requires repositioning of tack strips, and results in higher lumber use.
- To maximize shop efficiency: cut gussets; rip lumber; pre-cut lengths; cut out slot assembly; assemble side, top, and end panels; attach hailscreen; final assembly. When building multiple units, performing similar actions for several traps at the same time will allow you to develop an assembly line process that cuts construction time per unit.
- **Slot width of 1.25 inches in slot assembly is critical.** Wider slots will increase non-target captures, including small raptors, which will feed on your decoy birds. Escapes by females may also increase with wider slots.
- Side panels attach to the outside of end panels. Nothing else will fit if you attach ends outside.
- During final assembly assemble in this order: end, side, side, top, top, dropping slot assembly (3 pieces), then finish with the other end.



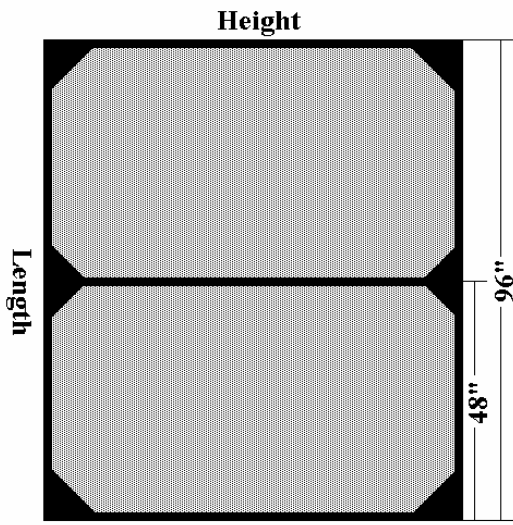

Left Side Panel (same as right panel)

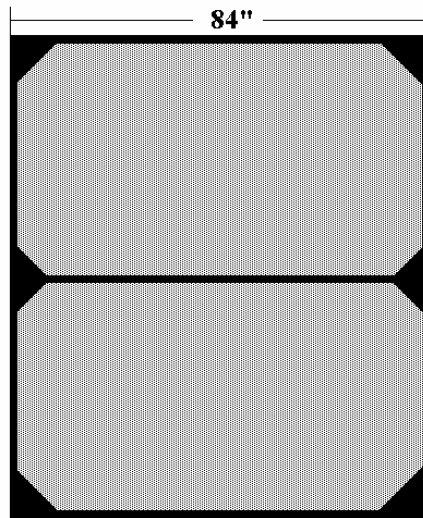

Right Side Panel

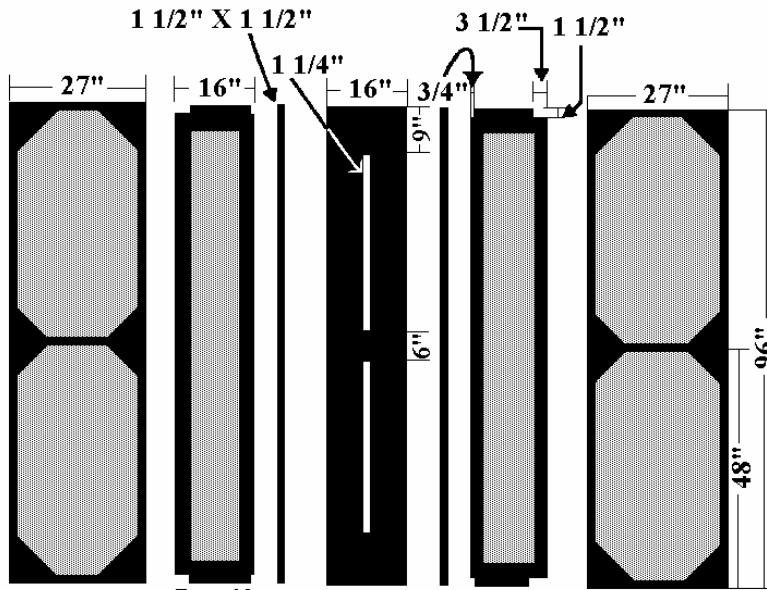

Top Panel/Slot Assembly

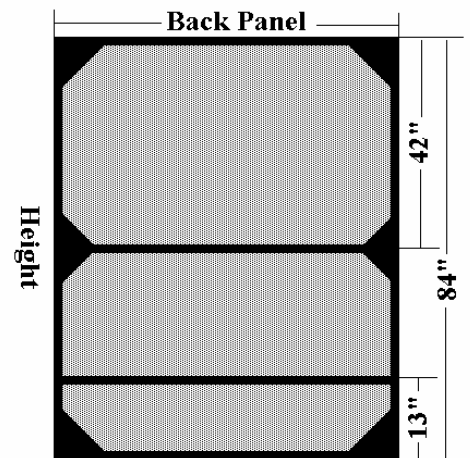

Back Panel

Cowbird Trap Plans

Plans developed by Fort Hood Environmental Division.

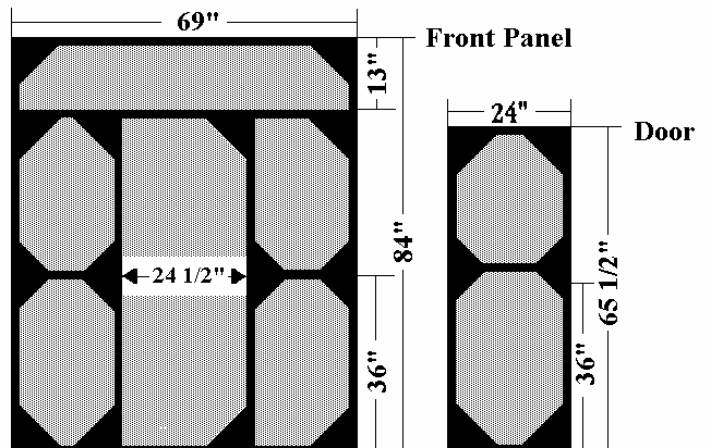

Materials List for 6x8 Portable Metal Cowbird Trap

| Number | Description | Comments |
|------------------|-----------------------------|-------------------------|
| 300 | 1 ½" fender washers* | attach wire to the trap |
| | frame | |
| 210 ft. | 1 ½" 14 gauge square tubing | frame |
| 16 ft. | 1 ½" x 1 ½" x ⅛" angle iron | trap funnel base |
| 15" w x 94 ½" lg | ⅛" plate* | funnel entrance floor |
| 2 | 2" weld-on hinges* | door hinge |
| 1 | weld-on door latch* | used to keep door |
| | secured | |
| 50 ft. of 48" | ½" hardware cloth | bought in 100 ft. rolls |
| 40 ft. of 36" | ½" hardware cloth | bought in 100 ft. rolls |

Recommended Tools:

| | |
|--|----------------------|
| 220 amp electric wire feed welding machine | Vise-grip pliers |
| Oxyacetylene cutting torch or pipe saw | 6 3 or 4 inch C- |
| clamps | |
| Electric drill and metal bits | Metal measuring tape |
| Driver for self-tapping metal screws | Wire brush |
| Hacksaw | Wire shears or tin |
| snips | |
| Hammer | Metal dirt rake |

Order of Construction: *(Refer to diagram for placement before welding)*

Sides (Cuts necessary for both sides)

- 2 cuts 96" of 1 ½" x 1 ½" 14 gauge square tubing (top of side panels).
- 2 cuts 96" of 1 ½" x 1 ½" heavy gauge square tubing (base of side panels).
- 4 cuts 81" of 1 ½" x 1 ½" 14 gauge square tubing (vertical corner posts).
- 2 cuts 93" of 1 ½" x 1 ½" 14 gauge square tubing (center braces).

Front

- 2 cuts 72" of 1 ½" x 1 ½" 14 gauge square tubing (door headers).
- 1 cut 72" of 1 ½" x 1 ½" heavy gauge square tubing (base piece).
- 2 cuts 11" of 1 ½" x 1 ½" 14 gauge square tubing (bracing over the door).
- 2 cuts 22 ¼" of 1 ½" x 1 ½" 14 gauge square tubing (mid-section bracing by door).

2 cuts 68 ½" of 1 ½" x 1 ½" 14 gauge square tubing (doorframe).

Door

3 cuts 21" of 1 ½" x 1 ½" 14 gauge square tubing (top, middle, bottom bracing).

2 cuts 68" of 1 ½" x 1 ½" 14 gauge square tubing (sides of door).

Back

3 cuts 72" of 1 ½" x 1 ½" 14 gauge square tubing (top, center frame pieces).

1 cut 72" of 1 ½" x 1 ½" heavy gauge square tubing (base piece).

2 cuts 11" of 1 ½" x 1 ½" 14 gauge square tubing (top bracing pieces).

Top

2 cuts 93" of 1 ½" x 1 ½" 14 gauge square tubing (upper frame for trap funnel).

2 cuts 93" of 1 ½" x 1 ½" x ⅛" angle iron. (lower trap entrance plate supports).

15" wide x 94 ½" long ⅛" plate (trap entrance plate). Cut two openings 36 ¼" x 1 ¼" as shown in the diagram. *The exact 1 ¼" width of each opening is critical. (Note: If desired, this plate can be made of wood, rather than metal.)*

Wire Mesh covering

Center the wire at the door and wrap it around the entire trap, using a dirt rake to pull the wire tight. Don't forget to cover the floor of the trap (this will help keep predators out). Attach the wire to the frame with fender washers and self-tapping screws placed every 12 inches apart.

Door: 1 piece 67 ¾" x 23 ½". Trim to fit.

Placement Notes:

A. ¼" gap on hinge side of door between door and frame.

B. Hinge starts 10" from the top.

C. Hinge starts 10" from the bottom.

***ALTERNATE CONSTRUCTION METHODS**

Attaching Wire Mesh (Alternate Method)

If desired, the screen mesh can be attached to the trap using 130 feet of 1" x ⅛" strap, and 275 self-tapping metal screws. Make the following cuts if this method is used:

Front: 2 – 74 ½”
2 – 23 ½”
2 – 27 ½”
2 – 11”

Both Sides: 6 – 95 ¾”
4 – 6”

Rear: 3 – 74 ½”
2 – 11 ½”
1 – 19”

Door: 3 – 23 ½”
2 – 21” (upper sides)
2 – 42 ¾” (lower sides)

Center Trap Angle: 2 – 93”

Hold all screen in place with 1" x ⅛" plate with screws placed every 6 inches.

Alternate Door Hinges and Latch Construction:

Note: Put door latch on first, then install frame latch to fit.

1 ft. of 1” x ¼” strap
2 ft. of ⅜” tubing
2 ft. of 7/16” rod

Make the following cuts:

4 cuts 2” of 3/8” tubing (door hinge part)
2 cuts 5” of 7/16” rod (door hinge part)
1 cut 7” of 1” x ¼” strap (door latch)
1 cut 5” of 1” x ¼” strap (on door)
1 cut 2” of 3/8” tubing (on door)
1 cut 3 ¼” 7/16” rod

Alternate Trap Entrance Plate:

2 pieces of plate 7” wide x 94 ½” long, separated by 1 ¼” inches that will form the opening. *The exact 1 ¼” width of the opening is critical.*

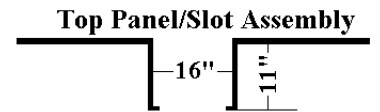
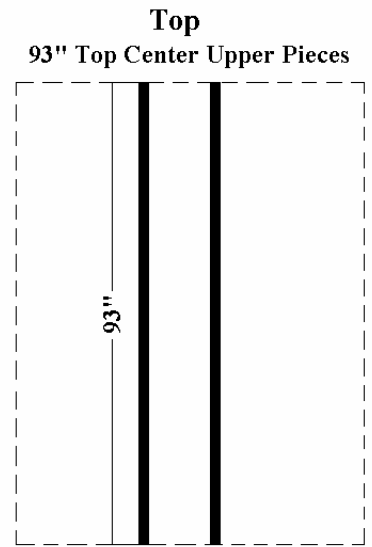
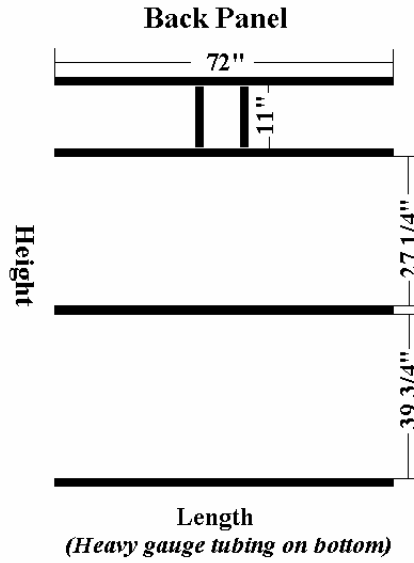
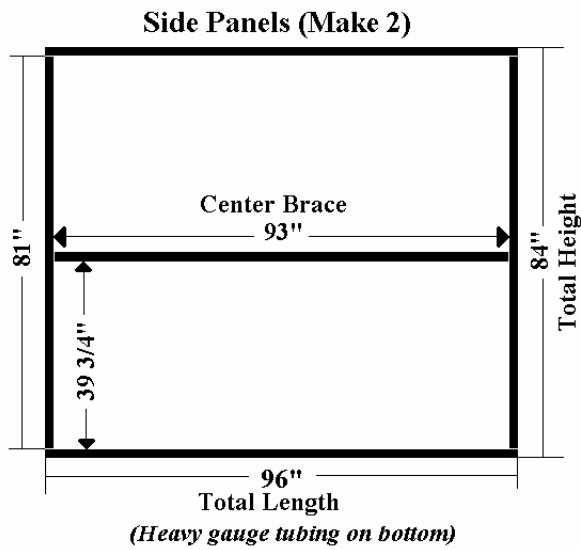

End View of Top Panel/Slot Assembly
Lower Cross pieces 93" angle iron

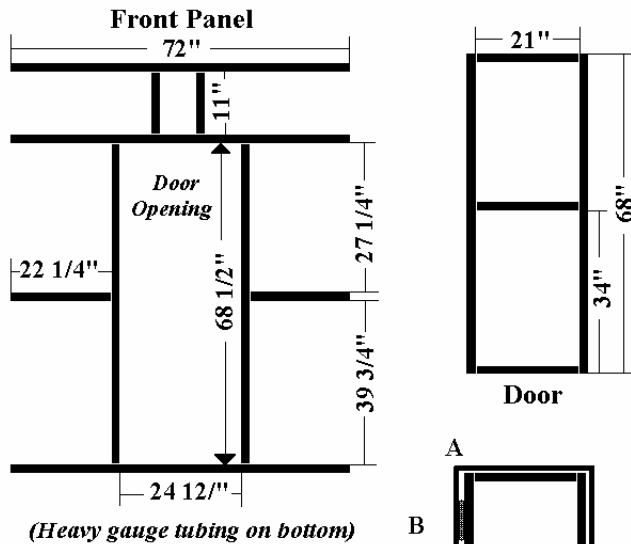
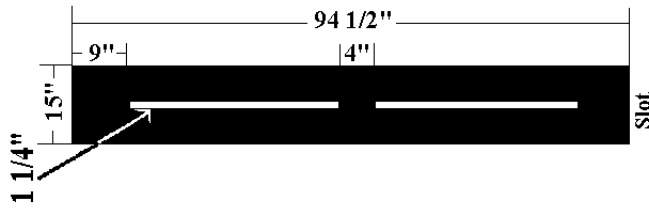

Door Latch Assembly

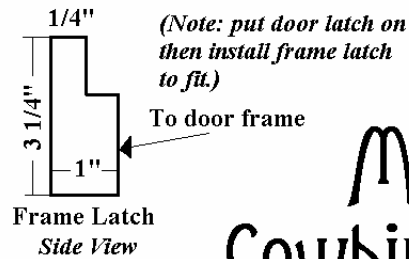
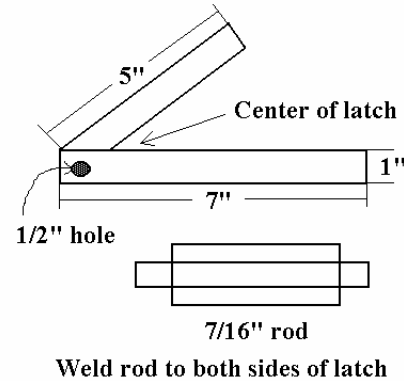

- A. 1/4" gap between hinge side of door between door and frame.
- B. Hinge starts 10" from top.
- C. Hinge starts 10" from bottom.

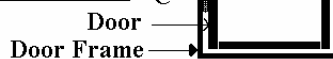

Metal Cowbird Trap Plans